

Thank you for your purchase of a Microlog Technologies product.

The Microlog DMM-3-BR12 and DMM-4-BR12 Battery/DC System Monitor are precision digital instruments measuring the battery state by monitoring the voltage status of 2 or 3 batteries or battery banks in boats and recreational vehicles (RV'S), with a resolution to 0.01V. The monitor is also designed to monitor current flow of charging devices, equipment current consumption or NET current flow, up to 200A, with a resolution to 0.1A (swk-201 shunt kit needed).

### Measuring Voltage:

Voltage indication is a prime way to learn the status of charge of your batteries. This voltage also corresponds to the level of specific gravity related to any given level of charge. The typical status of charge of your batteries is shown in the following table and chart, readings will vary with type and capacity of your batteries:

A Lead-Acid Battery voltage level of 11.70 Volts at rest (no load or charging device), indicates a completely discharged battery, while a voltage level of 12.70Volts (12.90 Volts/Gel-cell), without any charging device connected, indicate a full charged battery (at 77°F

| Percent of charge | Battery Voltage at rest (no load or charging device) |          |        | Lead-acid Battery Voltage (under load, C/10 no charging device) | Specific Gravity |
|-------------------|--|----------|--------|---|------------------|
|                   | Lead-acid  | Gel-Cell | AGM    |   |                  |
| 100%              | 12.7 V   | 12.9 V   | 12.8 V | 12.5 V  | 1.255-1.275      |
| 75%               | 12.4 V   | 12.6 V   | 12.6 V | 12.3 V  | 1.215-1.235      |
| 50%               | 12.2 V   | 12.3 V   | 12.3 V | 12.1 V  | 1.200-1.180      |
| 25%               | 12.0 V   | 12.0 V   | 12.0 V | 11.6 V  | 1.165-1.155      |
| 0%                | 11.7 V   | 11.8 V   | 11.8 V | 11.0V   | 1.130-1.110      |

Table 1: Typical Battery Voltage vs % of charge chart at 77°F (25°C) (according to a major battery manufacturer)

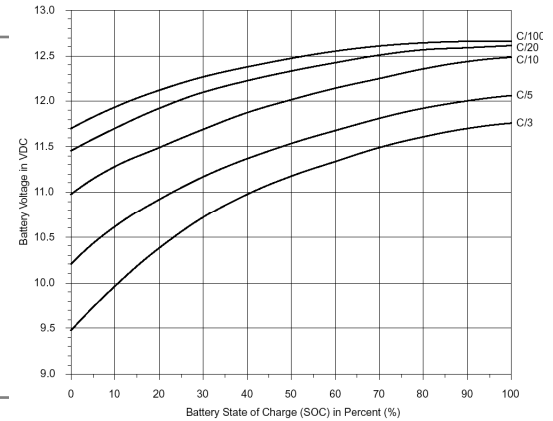

(25°C) temperature). Any battery that discharges often below 11.60 volts (50%, under load) will eventually shorten its service life.

### Measuring Current:

The Microlog instrument can be used to measure the value of current supplied to batteries MINUS consumption, as NET value, OR a choice between Charge / Discharge current only. Current flow is indicated by a + or - sign. Current measurement is determined by creating a very small voltage drop (de 0 to 200 millivolts) in a shunt (included in the Shunt and wiring kit) connected to the **Negative** side of batteries or charging and/or discharging devices. Your instrument convert this measurement to display a current reading. All measured current **MUST** pass through the shunt.

### The different Battery Charging Stages monitored with your instrument :

1-The BULK stage of charging is the first stage and the AMP level will be equal to the maximum output delivered by your charging equipment for between 25-75% of your Amp-Hour battery capacity. 2-The second stage called Absorption stage will provide the remaining 25% of charge to the battery (ies) where they will be considered fully charged with a remaining current of 2-4% of the AH battery capacity with a voltage of 14.4 Volts (14.2 for gels). 3-The Float Phase stage will maintain the battery charge after the full charge point has been reached.

The alternator, or other charging devices, will raise the battery (ies) voltage to 14.4 Volts (14.2 for Gel-Cell). This voltage information combined with the level of current supplied will tell you when you have reached the full charge status.

## INSTALLATION

The instrument must be located inside the boat or vehicle in order to protect it from weather damage. Choose a location, which is accessible, close to the electrical panel, or close to navigational equipment. Be sure to have sufficient space behind the panel to allow wire leads to be connected easily.

**IMPORTANT NOTICE: You MUST use 0.1 Amp fusing close to the each battery positives for instrument wiring protection.**

### >Installing the instrument for voltage measurement only (without shunt):

Figure 1 and Table 2 show the proper wiring installation of the instrument unit (without shunt) for voltage measurement only. The following steps will guide you through the procedures.

#### First do the following steps:

- 1- Align the instrument in intended position on the supporting panel on which it is to be installed and Mark the position of wire hole.
- 2- Drill 1/4" (6,3 mm) hole at the position of the wire passage through the supporting panel.
- 3- Clean the panel instrument position with alcohol or water with soap.
- 4- Feed the wires through the panel hole, peel the foam tape and position the instrument on the panel. Apply pressure on the instrument to stick in place.
- 5- Install the wiring from the battery compartment to the instrument.

**DO NOT CONNECT TO BATTERIES OR SHUNT NOW.**

- 6- Connect the instrument wires to the screw terminal strip first. Connect the BLACK, BROWN and BLUE wires together to the screw#1. Then connect the

GREEN (on DMM-4), WHITE and RED.

- 7- Connect the wires coming from the battery compartment to the instrument terminal strip.
- 8- Connect the BLACK wire to the batteries Negatives (-).
- 9- Connect the GREEN (on DMM-4), WHITE and RED on the Battery Positives (+) through ring-connector fuses.
- 10- Connect the ORANGE power + to an electrical distribution panel switch, breaker or to the ignition.

| Screw# | Color  | Usage                              |
|--------|--------|------------------------------------|
| 1      | Black  | Negative(-) Battery                |
| 1      | Brown  | Connect to screw #1                |
| 1      | Blue   | Connect to screw #1                |
| 4      | Green  | Positive(+) Battery 3              |
| 5      | White  | Positive(+) Battery 2              |
| 6      | Red    | Positive(+) Battery 1 (HOUSE BANK) |
|        | Orange | Positive(+) Instrument Power       |

Table 2: Installation without shunt

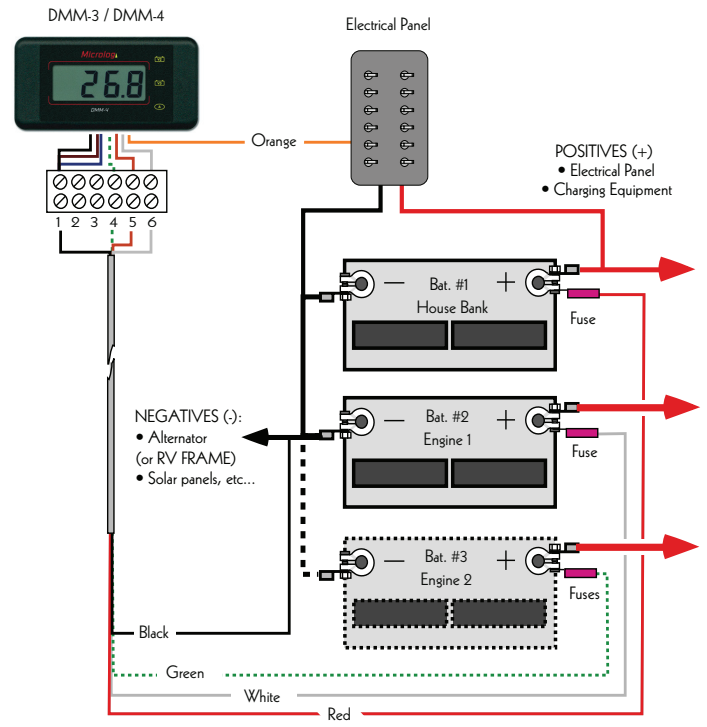

Figure 1: Installation without shunt

#### >Installation with shunt for current measurement.

You can choose to install a shunt in 3 different ways to measure current:

- A- You can choose to install the shunt as a House Bank NET current flow monitor with a charging (+) or a discharging (-) sign on the instrument as in Figure 2, It is the easiest way for a vehicle or RV.
- B- You can install the shunt to monitor the discharge current only, as in Figure 3.
- C- You can also install the shunt to monitor the charge current only, as in Figure 4.

**IMPORTANT WARNING:** We suggest you monitor just the house or service battery current flow, this is why:

Most boat and RV's alternators have their Negative output connected to the alternator casing and engine mass instead of having a separate Negative post. Engine starters are also connected the same way. If you connect the engine Negative mass wire to the shunt and then to the starting battery, this could lead to excessive current through the shunt, when starting. You can possibly damage the shunt and prevent the engine from starting. It is therefore very important, in the case you want to measure the starting batteries, to isolate the alternator negative from the mass and just connect the alternator to the shunt, so high starting surge current will not pass through the shunt. **DO NOT OVER-TIGHTEN BOLTS ON BRASS SHUNTS TOO MUCH AS THIS COULD DAMAGE SHUNT.**

- 1- Align the instrument in intended position on the supporting panel on which it is to be installed.
- 2- Mark the position of wire hole.
- 3- Drill 1/4" (6,3 mm) hole at the position of the wire passage through the supporting panel.
- 4- Clean the panel instrument position with alcohol or water with soap.
- 5- Feed the wires through the panel hole, peel the 3M foam tape and position the instrument on the panel. Apply pressure on the instrument to stick in place.
- 6- Install the wiring from the battery compartment to the instrument.

**DO NOT CONNECT TO BATTERIES OR SHUNT NOW.**

- 7- Connect the instrument wires to the instrument small terminal strip (see Table 3).
- 8- Connect the wires coming from the battery compartment to the terminal strip.
- 9- Connect the ORANGE (power and backlight) to an electrical distribution panel switch, breaker or to the ignition.
- 10- Install the shunt close to batteries. The Shunt **MUST** be mounted horizontally on a vertical wall to ensure the proper ventilation and cooling of the small shunt plates.

| Screw# | Color  | Usage                              |
|--------|--------|------------------------------------|
| 1      | Black  | Shunt Bat. Negative Side(-)        |
| 2      | Brown  | Shunt Bat. Negative Side(-)        |
| 3      | Blue   | Charge/discharge Negative Side(-)  |
| 4      | Green  | Positive(+) Battery 3              |
| 5      | White  | Positive(+) Battery 2              |
| 6      | Red    | Positive(+) Battery 1 (HOUSE BANK) |
|        | Orange | Positive(+) Instrument Power       |

Table 3: Installation with shunt

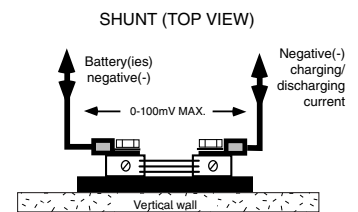

Shunt installation

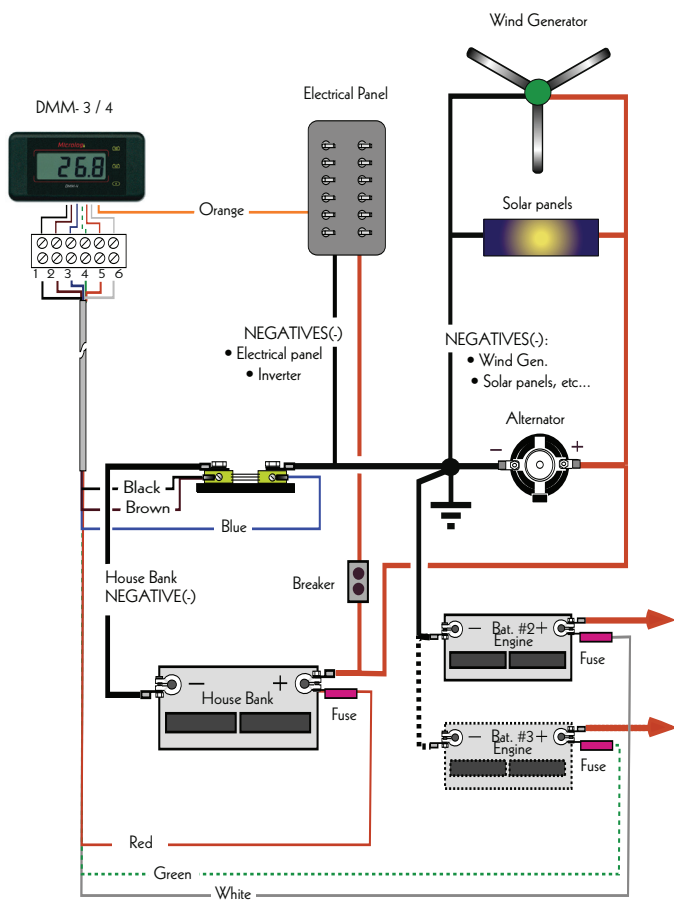

Figure 2: Installation with Shunt to measure the NET current value

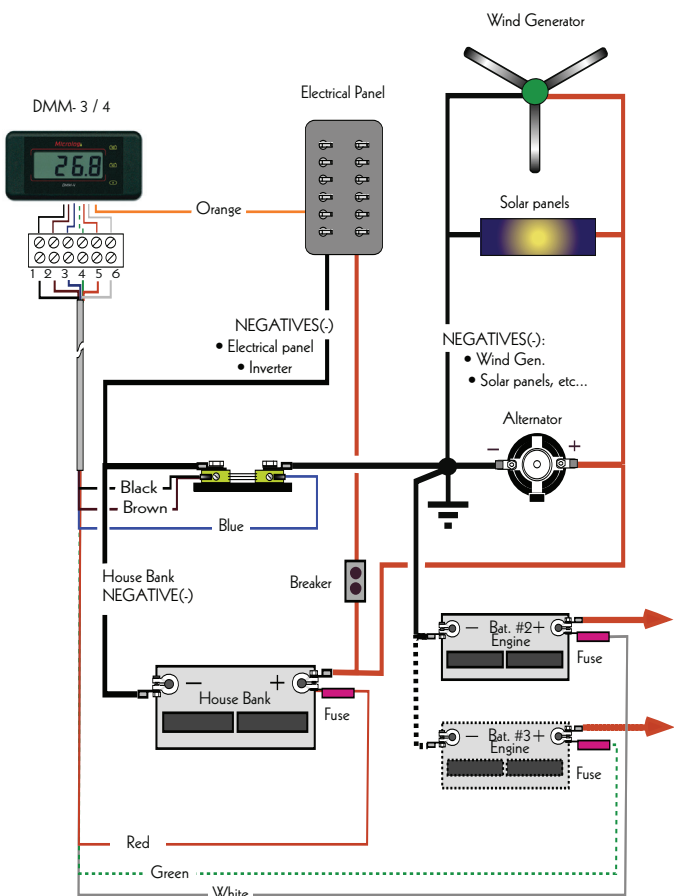

Figure 4: Shunt Installation to monitor the charge current

Continue with the following steps to install with a shunt according to the way you decide to install the shunt:

A- Figure 2 show the instrument with shunt to measure the NET value of current supplied to batteries :

11- Connect the **Negative (-)** terminal(s) of the battery (ies) to be monitored for current flow, to the **LEFT** side of Shunt. Use heavy gauge wiring to ensure good conductivity and provide heat dissipation.

12- All monitored charging and/or discharging equipment **Negative (-)** Cables, or engines/RV frame, should now be connected to the **RIGHT** shunt bolt.

DO NOT OVER-TIGHTEN BOLTS ON BRASS SHUNTS.

13- Connect the **BLACK, BROWN** and **BLUE** wires from the instrument terminal to the small screws on the Shunt.

14- Then connect the **GREEN** (on DMM-4), **WHITE** and **RED** on the Battery Positives (+) through ring-connector fuses to protect wiring.

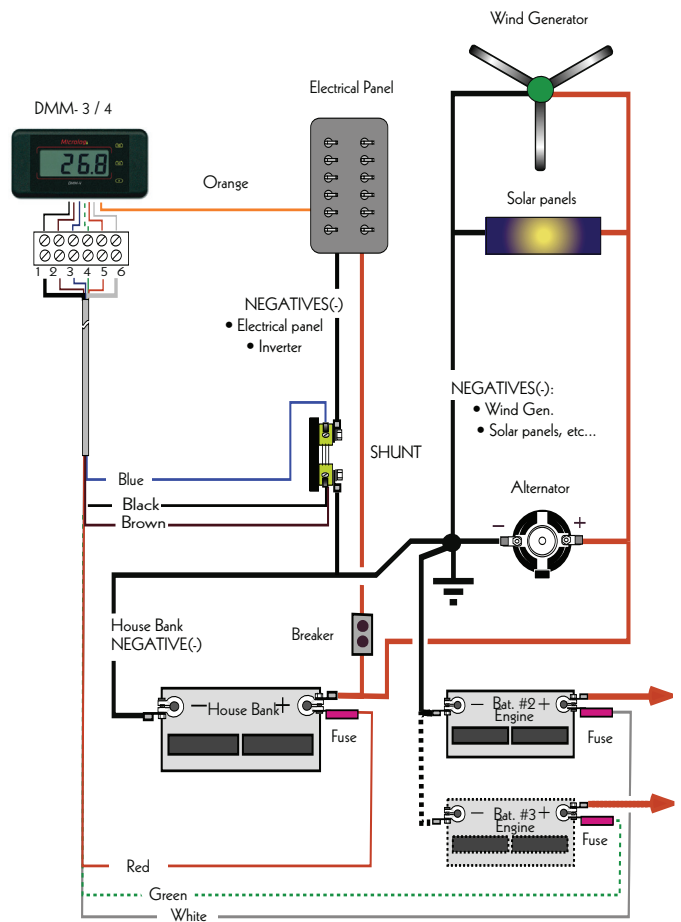

Figure 3: Shunt Installation to monitor the discharge current

B- Figure 3 show the instrument with shunt for discharge current monitoring only :

11- Connect the **Negative (-)** terminal(s) of the battery (ies) and charging equipment to the **RIGHT** side of Shunt. Use heavy gauge wiring to ensure good conductivity and provide heat dissipation.

DO NOT OVER-TIGHTEN BOLTS ON BRASS SHUNTS.

12- All monitored Discharging equipment **Negative (-)** Cables, should now be connected to the **LEFT** shunt bolt.

13- Connect the **BLACK, BROWN** and **BLUE** wires from the instrument terminal to the small screws on the Shunt.

14- Then connect the **GREEN** (on DMM-4), **WHITE** and **RED** on the Battery Positives (+) through ring-connector fuses to protect wiring.

C- Figure 4 show the instrument with shunt for chargers current monitoring only :

11- Connect the **Negative (-)** terminal(s) of the Charging equipment, to the **RIGHT**

side of Shunt. Use heavy gauge wiring to ensure good conductivity and provide heat dissipation.

DO NOT OVER-TIGHTEN BOLTS ON BRASS SHUNTS.

12- All discharging equipment and house battery **Negative (-)** Cables, should now be connected to the LEFT shunt bolt.

13- Connect the BLACK, BROWN and BLUE wires from the instrument terminal to the small screws on the Shunt.

14- Then connect the GREEN (on DMM-4), WHITE and RED on the Battery Positives (+) through ring-connector fuses to protect wiring.

## OPERATION

The **Instrument** displays Battery #1 Voltage if no other button is pressed.

The DMM-3 include 2 additional modes: Battery #2 Voltage and Current monitoring (AMPS).

The DMM-4 include 3 additional modes: Battery #2, Battery #3 Voltages and Current monitoring (AMPS).

Simply press the right button for the proper information. Current flow is indicated by a + or - sign.

## TROUBLESHOOTING

The **Instrument** does not work:

- Check instrument power on ORANGE wire, ring-connector fuses, small wires connections on batteries and terminal block.

The **Instrument** displays inaccurate voltage readings:

- Check ring-connector fuses, small wires connections on batteries and terminal block.
- Your VHF or SSB can induce your **Instrument** through the wiring network and increase the voltage reading slightly when transmitting.

The **Instrument** displays inaccurate current readings:

- Verify shunt installation for loose wiring and ensure that the all heavy wire gauge is well connected and bolted to the shunts.
- Check for Black, Brown and Blue wires are properly connected to shunt and Instrument terminal strip.
- All the measured current must pass through the Shunt in line with the **Negative** Wiring. For example: If you have equipment (s) **Negative (-)** (s) which are not connected through the Distribution Panel negative busbar, but rather on the Engine mass, boat keel or hull or RV frame instead. Discharge current reading will not all pass through the shunt and then you will get false reading.

## WARRANTY

Microlog technologies Inc. warrants to the original purchaser, only for 24 months from the date of purchase, that your instrument will be in good working order when properly installed and operated as described in this manual. AS WE HAVE ABSOLUTELY NO CONTROL ON THE WAY YOU INSTALL YOUR ELECTRICAL EQUIPMENT, ALL WARRANTIES ARE STRICTLY LIMITED TO THE INSTRUMENT FUNCTIONALITY AND NO OTHER EXPRESSED OR IMPLIED WARRANTY IS APPLICABLE. THE FOREGOING WARRANTY IS IN LIEU OF ALL OTHER WARRANTIES, INCLUDING THE WARRANTIES OF FITNESS FOR A PARTICULAR PURPOSE AND MERCHANT-ABILITY, EXPRESS OR IMPLIED, AND OF ALL OBLIGATIONS OR LIABILITIES ON THE PART OF MICROLOG TECHNOLOGIES INC. FOR DAMAGES, INCLUDING, BUT NOT LIMITED TO LOSS OF TIME, INCONVENIENCE, COMMERCIAL LOSS OR CONSEQUENTIAL DAMAGES, WHICH MAY ARISE OUT OF OR IN CONNECTION WITH THE USE OR PERFORMANCE OF THE INSTRUMENT.

Sogeman-Microlog Technologies Inc.

- Laval, Qc, Canada
- Tel.: 450.664.2664
- email : info@microlog-tech.com
- www.microlog-tech.com

v02/16